



**TOWN OF SOUTHERN SHORES**  
**TOWN COUNCIL MID-MONTH MEETING**  
5375 N. Virginia Dare Trail, Southern Shores, NC 27949  
Phone 252-261-2394 / Fax 252-255-0876  
www.southernshores-nc.gov  
**PITTS CENTER**  
**Tuesday, January 16, 2024 at 9:00 AM**

---

## **MINUTES**

### **Call to Order**

Pledge of Allegiance  
Moment of Silence

### **Present**

Mayor pro tem Matt Neal  
Council Member Paula Sherlock  
Council Member Mark Batenic  
Council Member Robert Neilson

### **Absent**

Mayor Elizabeth Morey

### **Approval of Agenda**

Motion made by Council Member Sherlock to approve the agenda as presented, Seconded by Council Member Batenic. The motion passed unanimously.  
Voting Yea: Mayor pro tem Neal, Council Member Sherlock, Council Member Batenic, Council Member Neilson

### **Business Items**

1. Minutes Approval (11.14.2023 & 12.05.2023)

**Motion** made by Council Member Batenic to approve the minutes of November 14, 2023 and December 5, 2023, Seconded by Council Member Sherlock. The motion passed unanimously.  
Voting Yea: Mayor pro tem Neal, Council Member Sherlock, Council Member Batenic, Council Member Neilson

2. Budget Amendment #23 (file room addition-Planning Dept.) & Award of Contract

Town Staff is requesting Budget Amendment #23 for additional funding for a 101 sq. ft. addition to the Planning & Code Enforcement Department's file room. Town Staff sent the construction drawings and requested bids from six contractors. Only one contractor submitted a bid.

Mayor pro tem Neal inquired about digitizing these files in the short term and looking at maybe a larger renovation of town hall as has been discussed previously.

Town Manager Ogburn did not have a price for digitizing the documents. He stated, the planning and permit department has everything that has ever been submitted for a property, a benefit which the citizens, contractors and real estate agents have grown accustomed to being able to come into town hall and sort through a file, making copies as necessary. Digitizing everything would be a shift to this practice and being a three-person department, the task would have to be contracted out.

Council Member Batenic asked Planning Director Haskett if other towns have digitized their documents. Planning Director Haskett stated most of the other towns in the county probably have purged the documents, as they are not required to keep them after a specific amount of time. Southern Shores has never purged permitting documents and he guesses that the other towns probably have purged their documents and not retained them as Southern Shores has historically done.

Council Member Neilson felt digitizing documents and the ability to access them has become common practice and digitizing the town's documents is important in the long term.

Mayor pro tem Neal stated depending on how pressing the need is for the Planning Department, he would recommend getting a cost to digitize a portion and/or the entire amount of documents and perhaps keep paper copies for a certain amount of years. Then look at some of the other town hall upgrades that are being considered; security upgrades and conference room upgrades, instead of dropping one lump sum on a small portion. There are most likely cost savings by doing it all at once. If the department could spare 45 days, he recommends looking into the concept of digitization.

Following the brief discussion, it was **consensus** of the council to get a quote on digital storage of the records. The council tabled the agenda item until staff could obtain an estimate on digitization of records and look at grouping together town hall improvements.

### 3. Budget Amendment #24-Ripple Fiber Street Repair

The agenda summary read as, On December 16, 2023, a sub-contractor doing work on behalf of Ripple Fiber cut a water line in the Town's right-of-way at approximately 156 S Dogwood Trl. The Dare County Water Department repaired the line. Three days later, the Town's Public Works staff noticed damage to the road caused by erosion from the leaking water line undermined the road putting it in need of immediate repair. Due to the emergency need for repairs, the Town contracted Hatchell Concrete for the work which was performed the same day the damage was noticed. The road was repaved the following day. Prior to fiber being installed in the Town rights-of-way, the Town entered into an encroachment agreement with Ripple Fiber and secured a performance guarantee to ensure that repairs to the Town's infrastructure are completed in an efficient and full manner. The performance guarantee is more than sufficient to cover the cost of repairs. This budget amendment is necessary for the Town to recognize the guarantee and pay Hatchell Concrete. Town Staff has invoiced Ripple Fiber for the expense which will return the performance guarantee to its full amount. Failure to pay by Ripple Fiber will put them in default of the encroachment agreement and result in a stop work order until payment is received.

**Motion** made by Council Member Batenic to approve budget amendment #24, Seconded by Council Member Neilson. The motion passed unanimously.

Voting Yea: Mayor pro tem Neal, Council Member Sherlock, Council Member Batenic, Council Member Neilson

4. Consideration of Historic Landmarks Commission (HLC) Application Submittal -13 Skyline Rd.

Town staff is requesting that the Town Council direct staff to start the process for consideration of designating Town owned property at 13 Skyline Rd as a Historic Landmark. If directed, staff will submit the application for review and recommendation from the Town’s Historic Landmark Commission

All of the council was in favor of directing staff to submit an application to designate 13 Skyline drive as a Historic Landmark.

**Motion** made by Council Member Batenic to direct staff to apply for designation of 13 Skyline Rd., Seconded by Council Member Sherlock. The motion passed unanimously.

Voting Yea: Mayor pro tem Neal, Council Member Sherlock, Council Member Batenic, Council Member Neilson

**General Public Comment**

Linda Barker-231 13<sup>th</sup> Ave- speaking regarding the feasibility study in Duck as it pertains to 13th Avenue in Southern Shores. 13 Avenue homeowners greatly oppose the sidewalk installation on the west side of Route 12 from Duck south of Jay Crest to Sea Oats in Southern Shores, if installed an extraordinary number of Duck renters will cross Route 12 onto 13th Avenue to use our street to access our beach, reducing the character of our peaceful tranquil neighborhood and beach area for southern Shore homeowners and vacationers. The people renting in Duck need to use Duck access to their beaches. The intersection of Route 12 with Sea Oats Ave. and 13th Avenue has serious flooding issues when it rains, it is dangerous to navigate in a vehicle much less a sidewalk. This issue must be addressed and resolved before a sidewalk can be considered.

**Closed Session**-pursuant to N.C.G.S. § 143-318.11(a)(3)

**Motion** made by Council Member Sherlock to enter a closed session pursuant to N.C.G.S. § 143-318.11(a)(3) , Seconded by Council Member Neilson. The motion passed unanimously.

Voting Yea: Mayor pro tem Neal, Council Member Sherlock, Council Member Batenic, Council Member Neilson

**Adjourn**

Upon returning to open session and taking no further action, **Motion** made by Council Member Batenic to adjourn the meeting at 11:02 a.m., Seconded by Council Member Neilson. The motion passed unanimously.

Voting Yea: Mayor pro tem Neal, Council Member Sherlock, Council Member Batenic, Council Member Neilson

ATTEST:

Respectfully submitted,

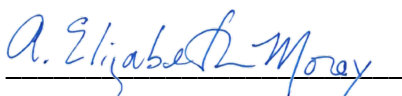

Elizabeth Morey, Mayor



Sheila Kane, Town Clerk

**Town of Southern Shores**  
**Budget Amendment Number # 23**

**Planning/Code Enforcement**

Increases			Decreases		
Account Number	Description	Amount	Account Number	Description	Amount
	<b><u>Revenues</u></b>				
40-39909	Unassigned Fund Balance	\$82,667			
	<b><u>Expenditures</u></b>				
63-50978	Town Building Update	\$82,667			
	<b>TOTAL</b>			<b>TOTAL</b>	\$ -

Explanation: Amount needed for file room expansion.

Recommended By:

\_\_\_\_\_  
 Cliff Ogburn, Town Manager

Approved By: Town Council

\_\_\_\_\_  
 Elizabeth Morey, Mayor

\_\_\_\_\_  
 Date

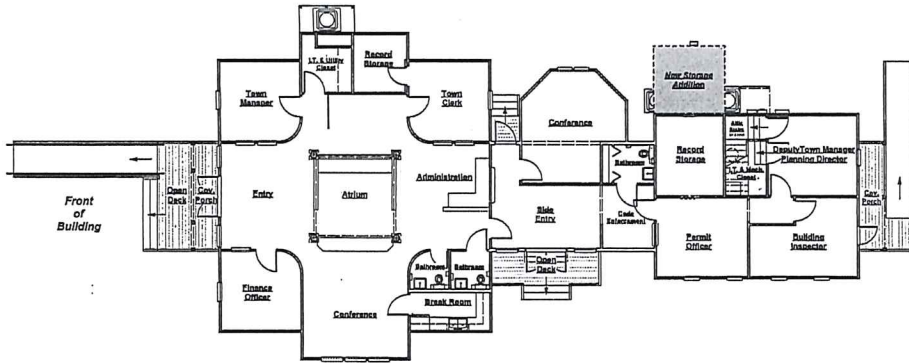

**OVERALL KEY PLAN**  
SCALE: NOT TO SCALE

AREA SCHEDULE	
EXISTING AREA	2,976 SQ.FT.
NEW STORAGE ADDITION	101 SQ.FT.
TOTAL AREA	3,077 SQ.FT.

WALL LEGEND	
	EXISTING WALL TO REMAIN
	EXISTING WALL TO BE REMOVED
	NEW WALL

**REMODEL & ADDITION NOTE:**  
 1. CONTRACTOR TO INSPECT ALL EXISTING STRUCTURE FOR ROT AND / OR MEMBER FAILURE, AND REPAIR OR REPLACE AT TIME OF CONSTRUCTION.  
 2. CONTRACTOR TO HAVE NEW STORAGE ADDITION CONSTRUCTION DRIED IN & SEALED FROM WEATHER, PRIOR TO DEMO. OF EXISTING STORAGE WALL & WINDOW. THE TOWN OF SOUTHERN SHORES WOULD LIKE TO USE THE EXISTING STORAGE ROOM PURING CONSTRUCTION OF THE NEW ADDITION.

**INTERIOR FINISH NOTE:**  
 1. CONTRACTOR TO MATCH ALL EXISTING INTERIOR FINISHES, SUCH AS: WINDOW & DOOR TRIM, BASE BOARD TRIM, DRYWALL FINISH, FLOORING & INTERIOR PAINT.

**WALL NOTE:**  
 1. ALL NEW ADDITION WALLS TO BE 2 x 4 STUDS AT 16" O.C., UNLESS NOTED OTHERWISE.

**GENERAL NOTE:**  
 1. CONTRACTOR TO FIELD VERIFY ALL CONSTRUCTION DIMENSIONS WITH EXISTING STRUCTURE. ALL DIMENSIONS SHOWN ARE TO FRAMED LUMBER, NOT INCLUDING DRYWALL OR WALL SHEATHING OR SIDING.

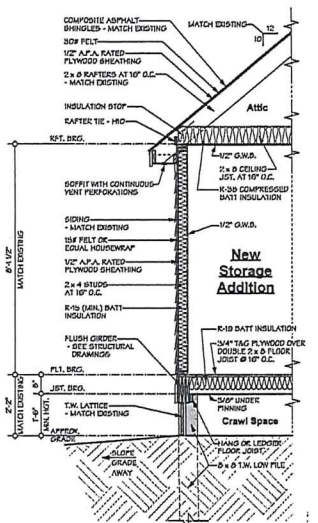

**1 WALL SECTION**  
SCALE: 1/2" = 1'-0"

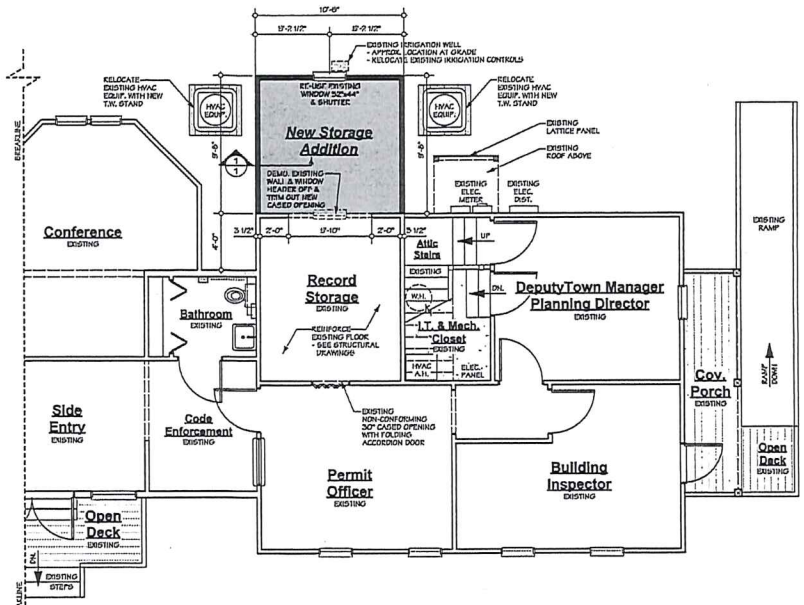

**PARTIAL FIRST FLOOR PLAN**  
SCALE: 1/4" = 1'-0"



CONSTRUCTION BY: FLOREZ DESIGN STUDIOS, P.C.  
 FLOREZ DESIGN STUDIOS, P.C.  
 1000 S. 10TH STREET, SUITE 100, WILMINGTON, NC 28401  
 TEL: 252-481-8000 FAX: 252-481-9928  
 WWW.FLOREZDESIGNSTUDIOS.COM  
 EMAIL: INFO@FLOREZDESIGNSTUDIOS.COM

**Addition to Town Hall**  
**Town of Southern Shores**  
 Location: 5375 North Virginia Dare Trail  
 Southern Shores, Dare County, NC

**FLOREZ**  
 DESIGN STUDIOS, P.C.  
 www.florezdesignstudios.com  
 P.O. Box 170, 418 Carolina Hwy.  
 Palm Harbor, NC 27854  
 Email: info@florezdesignstudios.com

PROJECT #	23-614
DATE	NOV. 8, 2023
SHEET #	1





**LEFT SIDE ELEVATION**  
SCALE: 1/4" = 1'-0"

**GENERAL NOTE:**  
1. CONTRACTOR TO FIELD VERIFY ALL CONSTRUCTION DIMENSIONS WITH EXISTING STRUCTURE. ALL DIMENSIONS SHOWN ARE TO FRAMED LUMBER, NOT INCLUDING DRYWALL OR WALL SHEATHING OR SIDING.

**EXTERIOR FINISH NOTE:**  
1. CONTRACTOR TO MATCH ALL EXISTING EXTERIOR FINISHES, SUCH AS SIDING, TRIM LATTICE, OVERHANG, FASCIA, VENTED SOFFIT, COMPOSITE ASPHALT SHINGLES & EXTERIOR PAINT.



**REAR ELEVATION**  
SCALE: 1/4" = 1'-0"



**FRONT ELEVATION**  
SCALE: 1/4" = 1'-0"

**NOTE:**  
NO ADDITIONS OR ALTERATIONS TO FRONT OR RIGHT SIDE ELEVATIONS.

FLOREZ DESIGN STUDIOS, P.C.  
 10000 W. HARRIS BLVD., SUITE 100  
 FARMERSVILLE, NC 27534  
 TEL: 252-481-9972  
 FAX: 252-481-9973  
 WWW.FLOREZDESIGNSTUDIOS.COM  
 EMAIL: INFO@FLOREZDESIGNSTUDIOS.COM

**Addition to Town Hall**  
**Town of Southern Shores**  
 Location: 5375 North Virginia Dare Trail  
 Southern Shores, Dare County, NC

**FLOREZ**  
**DESIGN STUDIOS, P.C.**  
 www.florezdesignstudios.com  
 Tel: 252-481-9972  
 Fax: 252-481-9973  
 Email: info@florezdesignstudios.com

PROJECT #	23-614
DATE	NOV. 8, 2023
SCALE	AS NOTED
DRAWN BY	LM, CH
REVISIONS	
SHEET #	2

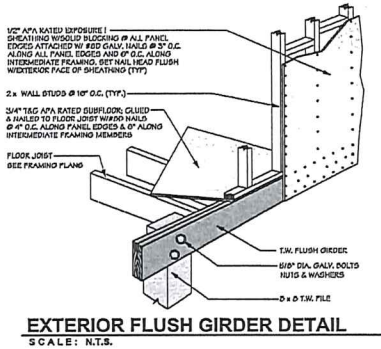
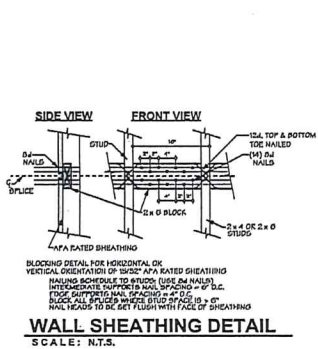

- FOUNDATION NOTES:**
- FILES SHALL BE 0" X 0" P.T. WITH EMBEDMENT DEPTH OF - 0"-0" FROM EXISTING GRADE (MIN.) & TAMPED TO REFUSAL OR AS PER ENGINEER.
  - CONTRACTOR RESPONSIBLE TO VERIFY ELEVATION OF SEAT CUT COMPLIES WITH COMMUNITY, LOCAL, AND STATE ORDINANCES.
  - GIRDER MATERIAL SHALL BE 2 X 12 #2 SOUTHERN YELLOW PINE PRESERVATIVE TREATED U.L.O.
  - METAL FASTENERS SHALL BE HOT-DIPPED GALVANIZED FINISH.
  - IT IS THE RESPONSIBILITY OF THE CONTRACTOR TO INSURE PROPER INSTALLATION OF ALL METAL FASTENERS PER MANUFACTURER'S SPECIFICATIONS.
- GIRDER/BEAM NOTE:**
- FOR ALL TRIPLE (OR QUAD) MEMBER GIRDERS OR BEAMS, NOTCH FILINGS FOR TWO MEMBERS, INSTALL THIRD (OR FOURTH) MEMBER BETWEEN FILINGS AND DOLT OR SCREW TOGETHER.
- FLOOR BLOCKING NOTE:**
- PROVIDE SOLID BLOCKING OR METAL BRIDGING AT MIDSPAN OF FLOOR JOIST OVER 0'-0" LONG, TYPICAL.

- LUMBER NOTE:**
- ALL FLOOR JOIST, DECK JOIST, GIRDERS, DEAMS, CEILING JOIST & RAFTERS TO BE #2 SOUTHERN YELLOW PINE, UNLESS NOTED OTHERWISE. ANY SUBSTITUTIONS TO BE COORDINATED BY THE CONTRACTOR, WITH THE STRUCTURAL ENGINEER.
- FRAMING NOTES:**
- HANG OR LEDGER, ALL JOIST AT FLUSH GIRDER & FLUSH DEAM LOCATIONS.
  - ENGINEERED LUMBER SHALL BE INSTALLED PER MANUFACTURER'S SPECIFICATIONS.
- GENERAL NOTE:**
- CONTRACTOR TO FIELD VERIFY ALL CONSTRUCTION DIMENSIONS WITH EXISTING STRUCTURE. ALL DIMENSIONS SHOWN ARE TO FRAMED LUMBER, NOT INCLUDING DRYWALL OR WALL SHEATHING OR SIDING.

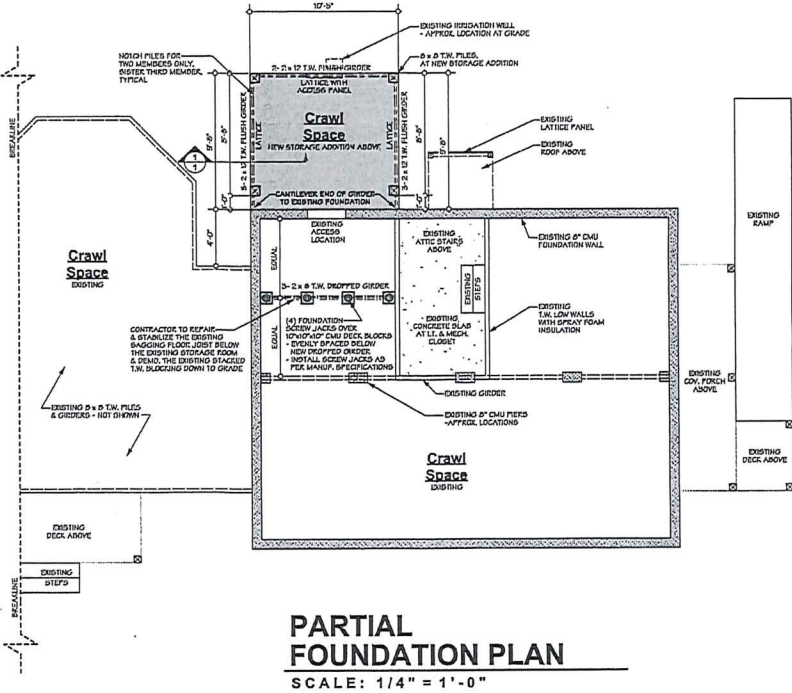
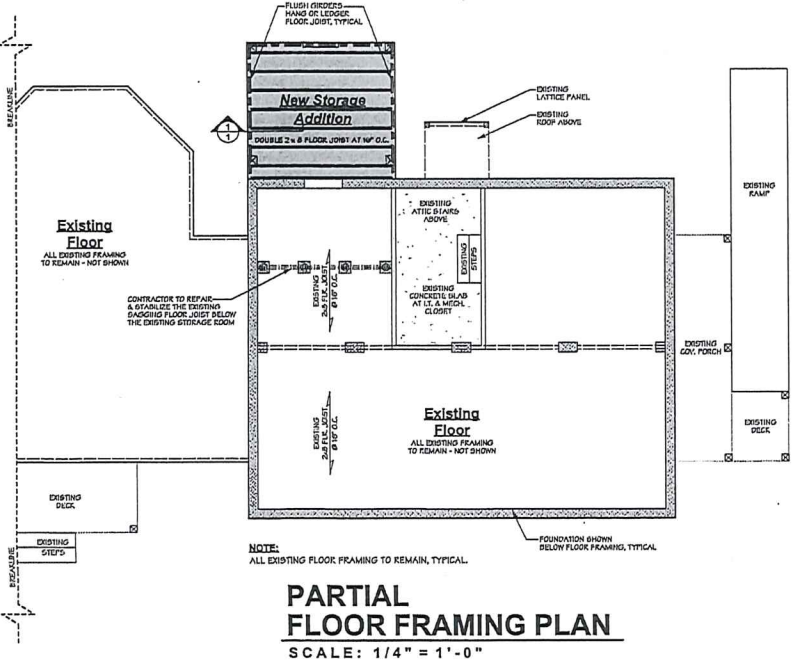

**Addition to Town Hall**  
**Town of Southern Shores**  
 Location: 5375 North Virginia Dare Trail  
 Southern Shores, Dare County, NC

Registered Professional Engineer  
 No. 23-014  
 Exp. 12/31/2024  
 Paul H. Hester, P.E.



THESE PLANS HAVE BEEN PROPERLY EXAMINED BY THE ENGINEER. I HAVE DETERMINED, TO THE BEST OF MY KNOWLEDGE AND BELIEF, THAT THEY COMPLY WITH EXISTING LOCAL NORTH CAROLINA CODES, AND HAVE BEEN PROPERLY AND ADVISORILY FOR USE IN THIS AREA.

SCALE: AS NOTED	EXAMINER: P.H.H.
DATE: NOV. 8, 2023	REVISIONS:
PROJECT # 23-014	SHEET #
<b>S1</b>	



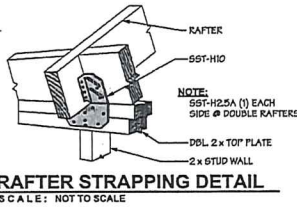
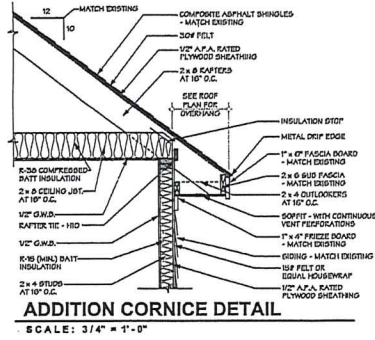

- ROOF FRAMING GENERAL NOTES:**
- SEE ROOF PLAN AND ELEVATIONS FOR PITCHES & LOCATIONS
  - ALL RAFTERS SHALL BE 2 x 8 @ 10' O.C. AT NEW ADDITION.
  - ALL EDGES TO BE (1) 2 x 12 WITH 2 x 8 RAFTERS U.L.D. (UNLESS UNLESS NOTED OTHERWISE) ALL OVERHANGS AND VALLEYS TO BE AS FOLLOWS:  
 0'-11" (1) 2 x 12  
 1'-0" (2) 2 x 12 OR (1) 12"x4" x 11' 7 1/2" LIE LV.  
 10'-20" (3) 12"x4" x 11' 7 1/2" LIE LV.  
 22'- (3) 12"x4" x 11' 7 1/2" LIE LV.  
 OR AS NOTED ON ROOF PLAN.
  - PROVIDE ROOF SUPPORT POSTS AND INTERIOR HEADERS AT MAIN ROOF MEMBERS AS SHOWN AND/OR REQUIRED
  - ALL FLAT CEILING AREAS SHALL BE 2 x 8 CEILING JOIST @ 10' O.C. U.L.D.
  - BLIND VALLEY REFERS TO THE INTERSECTION MADE WHEN A ROOF PLANE INTERSECTS ANOTHER ROOF PLANE. NO STRUCTURAL VALLEY MEMBER IS REQUIRED.
  - FASTEN ALL 1/2" RAFTERS TO 10" PLATE BY SIMPSON STRONG-TIE 1/2" x 6" NAIL PER MANUFACTURER'S SPECIFICATIONS (OR) CS90 WITH 5" END LENGTH (TYP.)
  - 1/2" / VALLEY MEMBERS SHALL BE FULL DEPTH SECTION ABOVE FINISHED CEILING ELEVATION (TYP.)

- ROOF VENTING NOTE:**
- PROVIDE ROOF / ATTIC VENTING AT ALL ROOF OVERHANGS & BOX VENTS AT THE UPPER THIRD OF THE ROOF, OR RIDGE VENTS AS REQUIRED, CONTRACTOR TO VERIFY.

- LUMBER NOTE:**
- ALL FLOOR JOIST, DECK JOIST, GIRDERS, BEAMS, CEILING JOIST & RAFTERS TO BE #2 SOUTHERN YELLOW PINE, UNLESS NOTED OTHERWISE. ANY SUBSTITUTIONS TO BE COORDINATED BY THE CONTRACTOR, WITH THE STRUCTURAL ENGINEER.
- FRAMING NOTES:**
- HANG OR LEDGER ALL JOIST AT FLUSH GIRDERS & FLUSH BEAM LOCATIONS.
  - ENGINEERED LUMBER SHALL BE INSTALLED PER MANUFACTURER'S SPECIFICATIONS.
- GENERAL NOTE:**
- CONTRACTOR TO FIELD VERIFY ALL CONSTRUCTION DIMENSIONS WITH EXISTING STRUCTURE. ALL DIMENSIONS SHOWN ARE TO FRAMED LUMBER, NOT INCLUDING DRYWALL OR WALL SHEATHING OR SIDING.

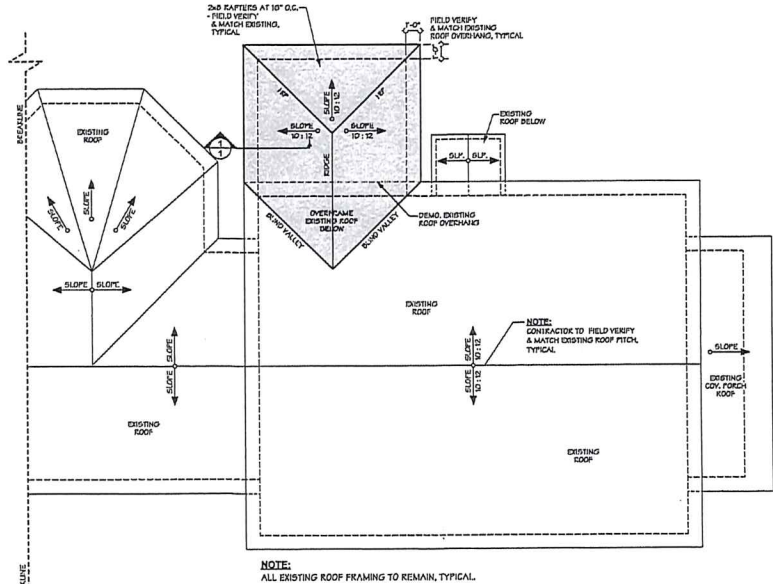
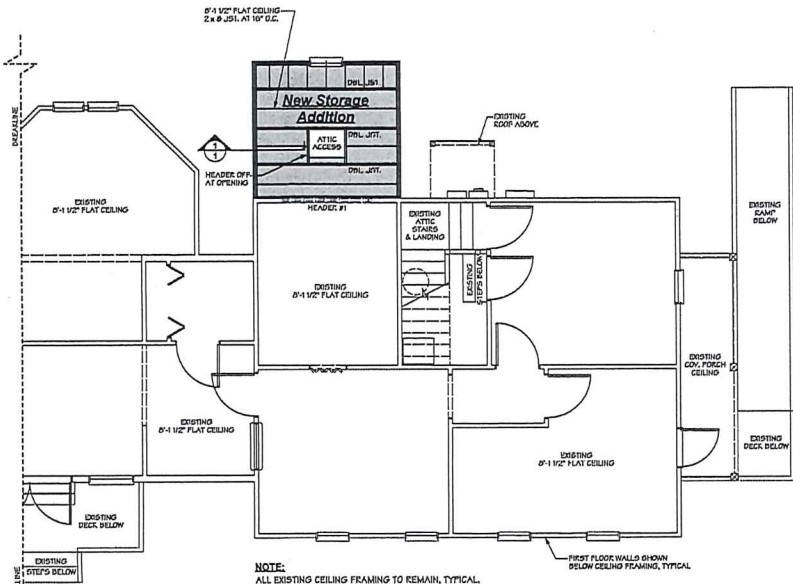

**Addition to Town Hall**  
**Town of Southern Shores**  
 Location: 5375 North Virginia Dare Trail  
 Southern Shores, Dare County, NC

Registered Civil Engineer, PE, P.L.L.C.  
 P.O. Box 228  
 Pottersville, NC 27884



\* THESE PLANS HAVE BEEN PROPERLY EXAMINED BY THE ENGINEER. I HAVE DETERMINED TO THE BEST OF MY KNOWLEDGE AND BELIEF, THAT THEY COMPLY WITH EXISTING LOCAL, NORTH CAROLINA CODES, AND HAVE BEEN PROPERLY SITE ADAPTED FOR USE IN THIS AREA.

PROJECT #	SCALE AS NOTED
25-014	CRANK: BT, MF, CH
DATE: NOV. 9, 2023	REVISIONS:
SHEET #	
<b>S2</b>	





## **Agenda Item Summary Sheet**

**Date:** 1/16/24

**Item #:** 3

**Item Title:** Budget Amendment #24-Ripple Fiber Street Repair

**Item Summary:** On December 16, 2023, a sub-contractor doing work on behalf of Ripple Fiber cut a water line in the Town's right-of-way at approximately 156 S Dogwood Trl. The Dare County Water Department repaired the line. Three days later, the Town's Public Works staff noticed damage to the road caused by erosion from the leaking water line undermined the road putting it in need of immediate repair. Due to the emergency need for repairs, the Town contracted Hatchell Concrete for the work which was performed the same day the damage was noticed. The road was repaved the following day.

Prior to fiber being installed in the Town rights-of-way, the Town entered into an encroachment agreement with Ripple Fiber and secured a performance guarantee to ensure that repairs to the Town's infrastructure are completed in an efficient and full manner. The performance guarantee is more than sufficient to cover the cost of repairs. This budget amendment is necessary for the Town to recognize the guarantee and pay Hatchell Concrete. Town Staff has invoiced Ripple Fiber for the expense which will return the performance guarantee to its full amount. Failure to pay by Ripple Fiber will put them in default of the encroachment agreement and result in a stop work order until payment is received.

**Staff Recommendation:** Approval of budget amendment.

**Requested Action:** A motion to approve budget amendment #24

**Attachment:** Budget Amendment #24





**Agenda Item Summary Sheet**

**Date: 1/16/24**

**Item #: 4**

**Item Title:** Consideration of Historic Landmarks Commission (HLC) Application Submittal – 13 Skyline Rd

**Item Summary:** Town staff is requesting that the Town Council direct staff to start the process for consideration of designating Town owned property at 13 Skyline Rd as a Historic Landmark. If directed, staff will submit the application for review and recommendation from the Town’s Historic Landmark Commission

**Requested Action:** A motion to direct staff to make the application to designate 13 Skyline a Historic Landmark.